

TRITON

AS2000 SR

Thermostatic
Power Shower

**REGISTER ONLINE
ENTER A PRIZE DRAW**

**WIN
£100**

RETAIL VOUCHERS

VISIT OUR WEBSITE TODAY

TRITONSHOWERS.CO.UK/REGISTER

*PRODUCT REGISTRATION IS ONLY AVAILABLE
TO UNITS PURCHASED & INSTALLED IN THE UK*

FOR YOUR SERVICE REFERENCE

NOTE DOWN THE PRODUCT CODE BELOW
(FROM THE FRONT OR TOP OF THE BOX)

ALTERNATIVELY REGISTER BY TEL: 024 7637 8321

INSTALLATION AND OPERATING INSTRUCTIONS

Please read this book thoroughly and familiarise yourself with all instructions before commencing installation and keep it for future reference.

The mixer shower installation **MUST** be carried out by a suitably qualified person, **in the sequence of this instruction book.**



IMPORTANT SAFETY ADVICE

Failure to use genuine Triton parts may cause injury and invalidate your guarantee.

The shower unit **MUST BE** switched off at the isolating switch when not in use. This is a safety procedure recommended for all electrical appliances.



PLEASE READ THIS IMPORTANT SAFETY INFORMATION

Products manufactured by Triton are safe and without risk provided they are installed, used and maintained in good working order in accordance with our instructions and recommendations.

- ⚠ WARNING: DO NOT** operate the appliance if frozen, or suspected of being frozen. It must thaw out before using.
- ⚠ DO NOT** operate the appliance if the shower head or spray hose becomes damaged.
- ⚠ DO NOT** restrict flow out of the appliance by placing shower head in direct contact with your body.
- ⚠ DO NOT** operate the appliance if water ceases to flow during use or if water has entered inside the unit because of an incorrectly fitted cover.
- ⚠** The spray head must be descaled regularly.
- ⚠** Fit only shower heads recommended by the manufacturer and never fit any additional device to restrict the water outlet flow.
- ⚠** The outlet must not be connected to any tap or fitting other than those specified.
- ⚠** This appliance **must not** be connected to the water mains supply and not connected by a hose set.
The water inlet of this appliance shall not be connected to inlet water obtained from any other water heating system.
- ⚠ WARNING:** This appliance is not to be used to provide a potable water supply.
- ⚠** Always disconnect the appliance from the supply before assembling, disassembling or cleaning.

Minimum inlet pressure 0.075 metres 0.75kPa (0.0075 bar)
Maximum inlet pressure 10 metres 100kPa (1 bar)

This book contains all the necessary fitting and operating instructions for your power shower.

Care taken during the installation will provide a long, trouble-free life from your shower.

⚠ WARNING ⚠

This appliance can be used by children aged from 8 years and above and persons with reduced physical, sensory or mental capabilities or lack of experience and knowledge if they have been given supervision or instruction concerning use of the appliance in a safe way and understand the hazards involved. Children may not play with the appliance. Cleaning and user maintenance shall not be made by children.



IMPORTANT - PLEASE READ THESE GENERAL GUIDANCE NOTES BEFORE PROCEEDING



1 GENERAL

- 1.1** Isolate the electrical and water supplies before removing the cover.
- 1.2** Read all of these instructions and retain them for later use.
- 1.3 DO NOT** take risks with plumbing or electrical equipment.
- 1.4** Isolate electrical and water supplies before proceeding with the installation.
- 1.5** The unit must be mounted onto the finished wall surface (on top of the tiles). **DO NOT** tile up to or seal around **ANY PART** of the unit using silicone sealer after fixing to the wall.
- 1.6** Contact Customer Experience (*see back page for contact details*), if any of the following occur:
 - a)** *If it is intended to operate the shower at pressures above the maximum or below the minimum stated.*
 - b)** *If the unit shows a distinct change in performance.*
 - c)** *If the shower is frozen.*
- 1.7** If it is intended to operate the shower in areas of hard water (above 200 ppm temporary hardness), a scale inhibitor may have to be fitted. For advice on the scale inhibitor, contact Customer Experience.
- 1.8** The shower head must be cleaned regularly with descaler to remove scale and debris.
- 1.9** This product is not suitable for mounting into steam rooms or steam cubicles.

2 PLUMBING

- 2.1** The plumbing installation must comply with Water Regulations, Building Regulations or any particular regulations as specified by Local Water Company or Water Undertakers and should be in accordance with BS EN 806.
- 2.2 DO NOT** connect the shower unit to the mains cold water supply as it will damage the unit and the installation will be in breach of water regulations.
- 2.3** The supply pipe must be flushed to clear debris before connecting to the shower unit.
- 2.4 DO NOT** solder pipes or fittings within 300mm of the shower unit, as heat can transfer along the pipework and damage components.
- 2.5 DO NOT** use excessive force when making connections to the flexible hose or shower head, finger tight is sufficient.
- 2.6** All plumbing connections must be completed before making the electrical connections.
- 2.7** Water supplies must be turned on before switching on the electricity. The shower must not be operated dry without water.
- 2.8** This appliance **MUST NOT** be connected to the inlet supply by a hose-set.
- 2.9** When installed, the top of the shower unit must be at least 75mm lower than the base of the cold water storage cistern to prevent the pump being run dry without water.

- 2.10** A dedicated cold water supply must be taken directly from the cold water cistern to the shower. This draw-off must be on the opposite side of the cistern to the float operated valve to reduce the risk of air entering the unit.
- 2.11** The action of the pump is to increase the flow rate. If the supply pipework cannot handle the resulting flow rate then:
 - 2.11.1** The anticipated flow rate may not be achieved.
 - 2.11.2** Air may be drawn into the hot supply from the vent pipe causing spluttering and temperature fluctuations at the showerhead.
- 2.12** Fullway isolating valves must be fitted on the hot and cold water supplies to the shower as an independent means of isolating the water supplies should maintenance or servicing be necessary. Do not use stop taps or ball-o-fix type valves which restrict flow.

If this isolator is fitted in a loft space, the loft must have a fixed access ladder and be boarded, with appropriate lighting from the access point to the isolator.

3 ELECTRICAL

- 3.1** The installation must comply with BS 7671 'Requirements for electrical installations' (IEE wiring regulations), building regulations or any particular regulations as specified by the local Electrical Supply Company.
- 3.2** In accordance with 'The Plugs and Sockets etc. (Safety) Regulations 1994', this appliance is intended to be permanently connected to the fixed wiring of the electrical mains system.
- 3.3** Make sure all electrical connections are tight to prevent overheating.
- 3.4** Fuses do not give personal protection against electric shock. A 30mA residual current device (RCD) **MUST** be installed in all UK electric and pumped shower circuits. This may be part of the consumer unit or a separate unit.
- 3.5** Switch off immediately at isolating switch if water ceases to flow during use.
- 3.6** Other electrical equipment i.e. extractor fans, pumps, must not be connected to the circuits within the unit.
- 3.7** Switch off at isolating switch when not in use. This is a safety procedure recommended with all electrical appliances.
- 3.8** Do not turn on the electrical supply until the plumbing connections have been completed.
- 3.9** The mains supply must be 230/240V, at 50Hz, connected to the unit via a double pole switched 3 Amp fused connection unit (not supplied) with a minimum 3mm contact separation gap in each pole.
- 3.10** As with all electrical appliances it is recommended to have the shower and installation checked at least every two years by a competent electrician to ensure there is no deterioration due to age and usage.

CONTENTS

Page

INTRODUCTION	
IMPORTANT SAFETY INFORMATION & GENERAL GUIDANCE NOTES <i>(please read)</i>	
SPECIFICATIONS.....	5
MAIN COMPONENTS.....	6
WATER AND CABLE ENTRY POINTS.....	7
SITE REQUIREMENTS & RECOMMENDED INSTALLATION	8 - 9
GENERAL INSTALLATION NOTES.....	9
SITING OF THE SHOWER.....	10
PLUMBING CONNECTIONS.....	11 - 12
FITTING THE SHOWER TO THE WALL.....	12 - 13
ELECTRICAL CONNECTIONS.....	14
COMMISSIONING.....	15 - 16
TEMPERATURE CONTROL SET UP.....	17
OPERATING THE SHOWER.....	18
CLEANING THE FILTERS.....	19
FAULT FINDING.....	20 - 21
SPARE PARTS.....	22
GUARANTEE, SERVICE POLICY, ETC.....	REAR COVER

To check the product suitability for commercial and multiple installations, please contact Triton's specification advisory service before installation. Please see back of book for contact information.



Find our step-by-step installation video for this product on our YouTube channel. Go to [youtube.com/TritonShowers](https://www.youtube.com/TritonShowers) and search for 'how to guides'.

IMPORTANT

The shower installation must be carried out by a suitably competent person and in sequence of this instruction book.

Please read through the whole of this book before beginning your installation.

DO NOT use jointing compounds on any pipe fittings for the installation.

Switch off immediately at the isolating switch if water ceases to flow during use.

DO NOT operate the shower outside the guidelines laid out in 'site requirements'.

SPECIFICATIONS

Hot Water Temperature

Maximum temperature 65°C.

A stored water temperature of 60°C is considered sufficient to meet all normal requirements and will minimise the effects of scale in hard water areas.

Temperature Control

To obtain the maximum performance, this unit should be installed, operated and maintained as instructed in this book. Optimum performance is achieved with water supplies of 15°C cold and 60°C hot and with nominally equal pressures.

Maximum Static Inlet Pressure

100 Kpa (1 bar) or 10m (supplies must be gravity fed at nominally equal pressures).

Minimum Static Inlet Pressure

0.75 Kpa (0.0075 bar) or 75mm (required to prime the integral centrifugal pump).

Maximum Total Head 2m

This is the vertical distance that you are able to pump the water.

Fig.1

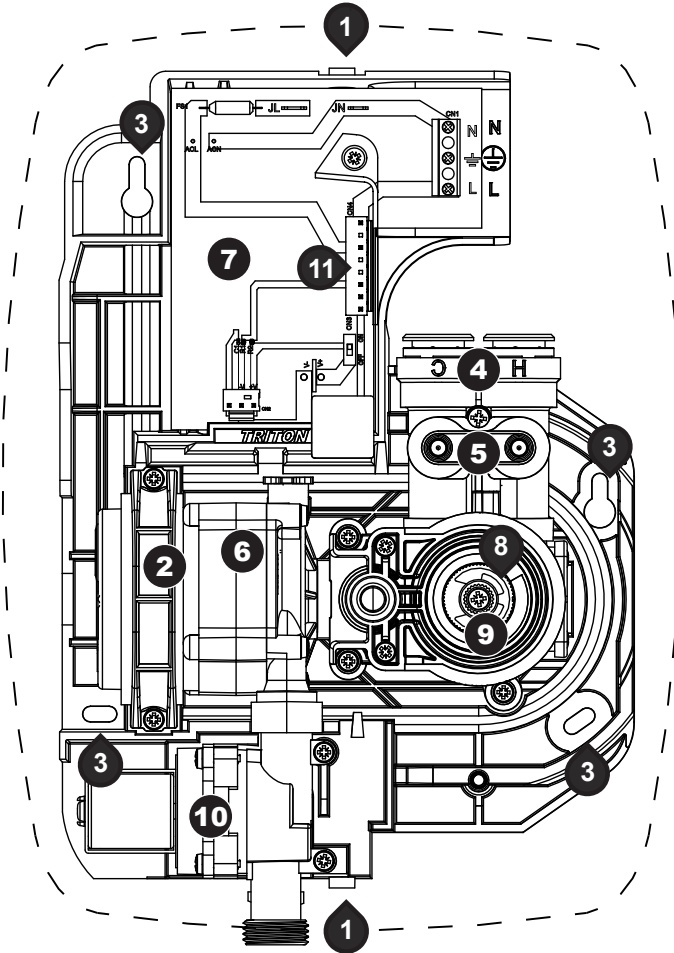

MAIN COMPONENTS

- | | |
|--|------------------------------|
| 1. Cover screw fixing | 7. PCB / power supply |
| 2. Motor retaining bracket | 8. Setting ring |
| 3. Wall fixing holes | 9. Temperature control valve |
| 4. Pipe inlets – swing
(contains single check valves) | 10. Solenoid outlet |
| 5. Filter cover | 11. Cover connector |
| 6. Pump | — — Cover outline |

Power Shower

Fig.2

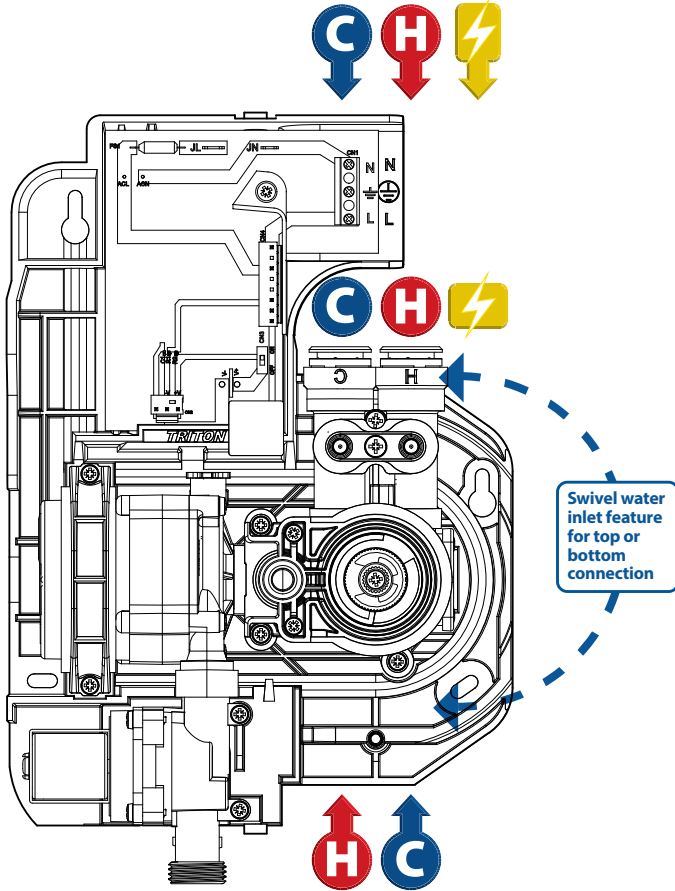

Entry Points Key:

  H & C Water
Rear Entry Entry Points

  Cable
Rear Entry Entry Points

Dimensions:

H: 292mm

W: 219mm

D: 115mm

Power Shower

Fig.3a - Recommended Installation - Diagrammatic view – not to scale

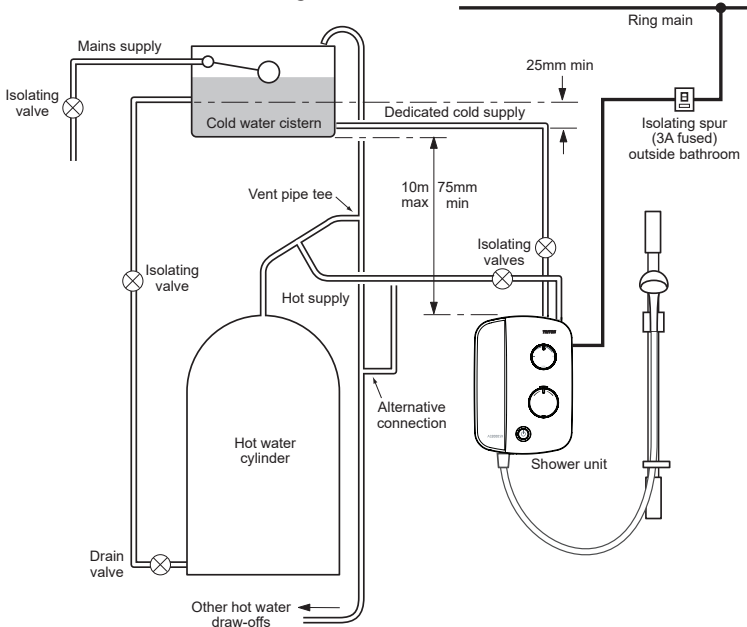
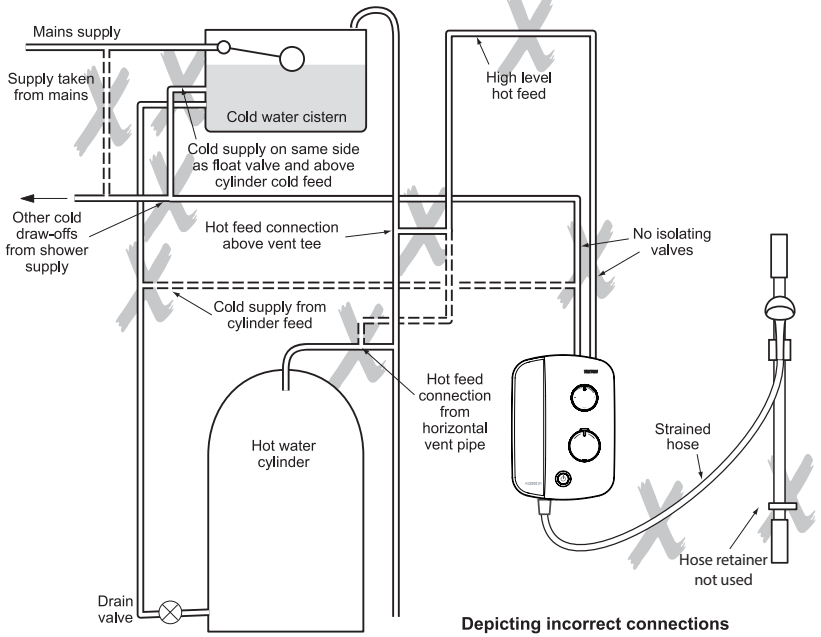

Fig.3b - Incorrect Connections - Diagrammatic view – not to scale



Depicting incorrect connections

SITE REQUIREMENTS

Water

The installation must be in accordance with Water Regulations/Bylaws and BS-EN 806.

For correct operation of this shower unit, both hot and cold water supplies to the appliance must be gravity fed, at nominally equal pressures, from a cold water storage cistern and a hot water storage cylinder. The water circuit should be installed so that the flow is not significantly affected by other taps and appliances being operated elsewhere on the premises.

Fig.3a shows a recommended installation where the hot water supply for the shower is made via a tee connection on the **underside of the horizontal section of pipework from the cylinder**. Alternatively, the connection can be taken from the hot supply pipe to other outlets as long as it is the first draw-off below the ventilation pipe tee.

IMPORTANT: Failure to conform to **Fig.3a** can allow air ingress into the product which can impair performance and may invalidate the guarantee.

Fig.3b illustrates incorrect connections that must be avoided.

All pipework to the shower unit must be routed where it remains below the level of water in the cistern. In the case of horizontal sections of pipework in lofts, it may be necessary to fit automatic air vents at high points on the supplies to remove the possibility of air locks.

For the operation of the shower only, it is recommended that the cold water storage cistern is capable of holding at least 114 litres (25 gallons). Where other hot and cold outlets are likely to be in use simultaneously, the storage capacity should be increased to 228 litres (50 gallons) in accordance with BS-EN 806.

DO NOT connect to a combination cylinder unless there is a guaranteed 114 litre cold supply to the cylinder as the shower can deliver up to 14 litres per minute. It is advisable to check that the infill rate from the float operated valve meets the output requirements. It is recommended that there is a minimum of approximately 114 litres (25 gallons) of hot water storage per appliance.

Under no circumstances should this product be connected to mains cold or hot water supplies. Failure to comply will invalidate the guarantee.

GENERAL INSTALLATION NOTES

1. DO NOT take risks with plumbing or electrical equipment.
2. Isolate electrical and water supplies BEFORE proceeding with installation work.
3. Shower control MUST be fed from a cold water storage cistern and hot water cylinder that provides nominally equal pressures.
4. If installing with rear inlet supplies, it is recommended the supply pipework is sealed to the wall so as to prevent water from leaking back into the wall.
5. In solid wall installations, the supply pipework should be housed within ducting in order to allow some free lateral movement when making connections and to ensure compliance with requirements of accessibility of pipes and pipe fittings.

Fig.4 shows a schematic wiring diagram of the unit.

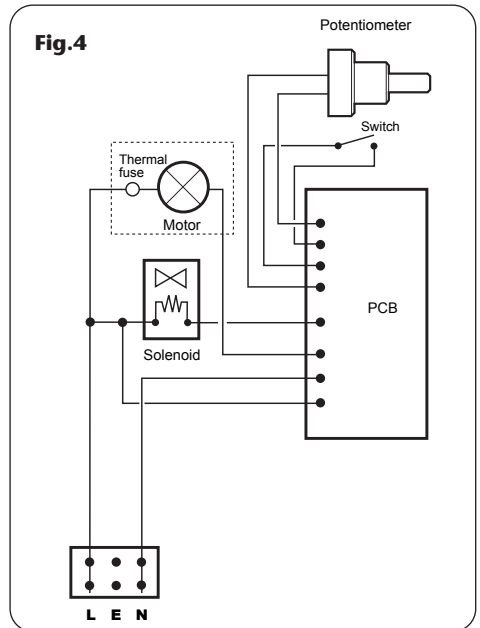

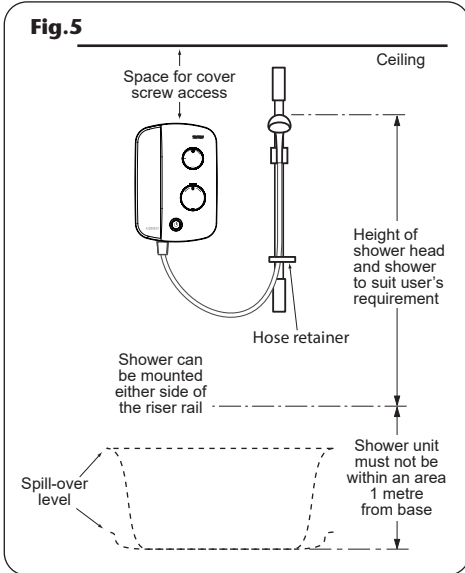

SITING OF THE SHOWER

WARNING!

The shower must not be positioned where it will be subject to freezing conditions.

IMPORTANT: The unit must be mounted onto the finished wall. NEVER tile up to the unit.

Refer to **fig.5** for correct siting of the shower.

Position the unit vertically where it will NOT be in direct contact with water from the shower head. Allow sufficient room between the ceiling and the shower unit to access the top cover screw.

Position the shower and shower head on the wall so that all controls can be comfortably reached when using the shower.

The shower head and riser rail can be positioned either side of the shower unit.

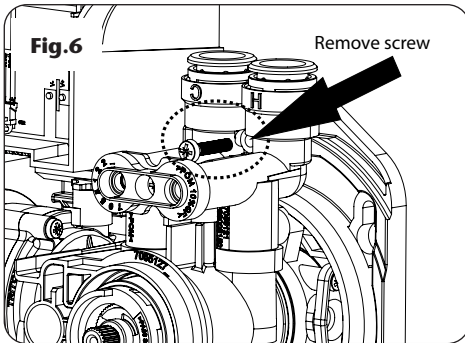

Note: Water Regulations require the shower head be 'constrained by a fixed or sliding attachment so that it can only discharge water at a point not less than 25mm above the spill-over level of the relevant bath, shower tray or other fixed appliance'. The use of the supplied hose retainer will in most cases meet this requirement, but if the shower head can be placed within a bath, basin or shower tray, then a device must be fitted to prevent back-flow.

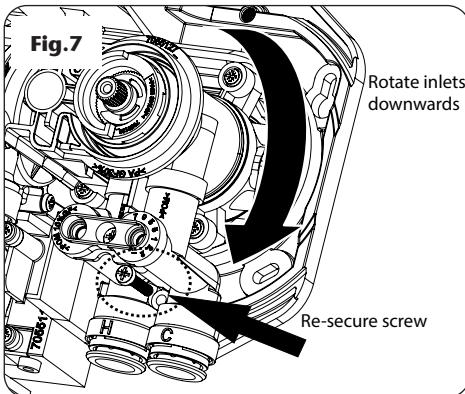

DECIDE ON WATER ENTRY

Decide the position of the shower in relation to water pipe entry. The unit will be supplied with the inlets in the upwards position for rear or upper entry.

If lower entry is required, carefully lift the cover away from the backplate and lay aside until later. Peel off the yellow sticker from the inlets and remove the inlet retaining screw (**fig.6**). Carefully rotate the inlets to the downwards position and re-secure with the screw (**fig.7**).

Note: Take care when rotating the inlets into a new position, to minimise the risk of damaging the valve. Under no circumstances should any of the torx screws on the valve be tampered with.

PLUMBING CONNECTIONS

Plumbing to be carried out before wiring

Note: The outlet of the shower must not be connected to anything other than the hose and shower head supplied.

When connecting pipework avoid using tight 90° elbows. Swept or formed bends will give optimum performance.

Isolate the mains water supply to the cold water cistern. Drain the hot and cold pipes by opening all taps.

The hot water supply can be taken from the hot supply pipe from the cylinder. Make sure that it is the first draw-off below the ventilation pipe tee in order to minimise the effects of water draw-off elsewhere in the house (**fig.3a**).

Note: There must not be any other draw-offs between the take-off point and the shower.

A dedicated cold water supply must be taken directly from the cold water cistern to the shower. This draw-off must be positioned 25mm below the cold feed connection to the hot water cylinder on the opposite side of the cistern to the float operated valve (**fig.3a**). This minimises air ingress into the pipework.

Plumbing options other than those outlined in these fitting instructions could impair the performance. For example, if hot and cold connections are made after draw-off points to other outlets, e.g. washing machine, taps, etc. it could result in unstable flows and temperatures should other appliances operate at the same time.

Run the hot and cold pipework to the shower position. To avoid air locks, make sure that the pipework does not rise above the level of water in the cold cistern at any point. Under normal site conditions 15mm pipework will be adequate.

Cut the pipework to the dimensions relevant to the chosen direction of water entry into the shower.

When fitting elbows to incoming pipework, ensure the elbows are fully engaged with the exposed pipe.

Dimensions are shown in **fig.8** and **fig.9**.

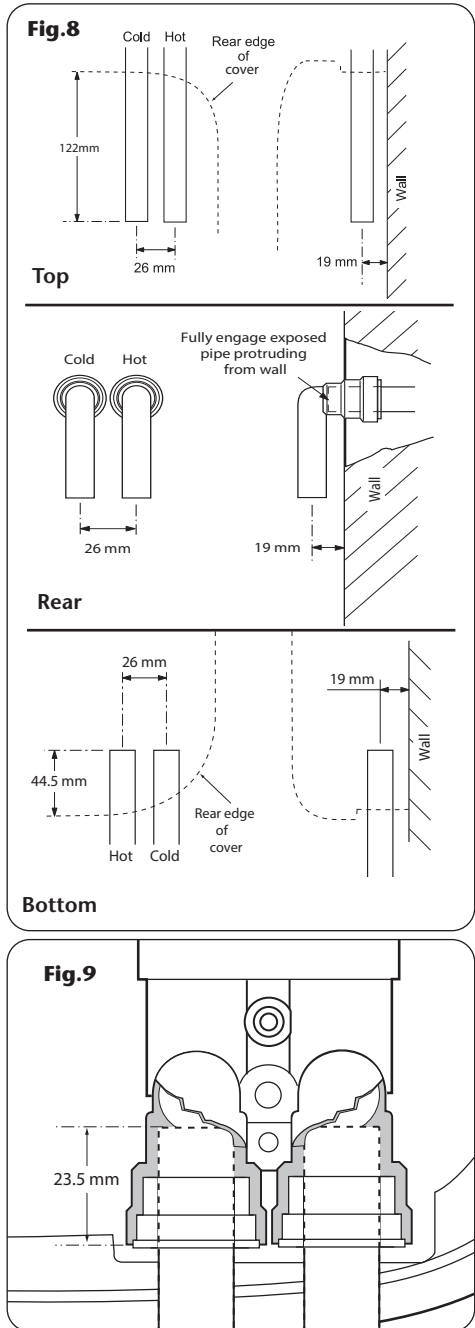

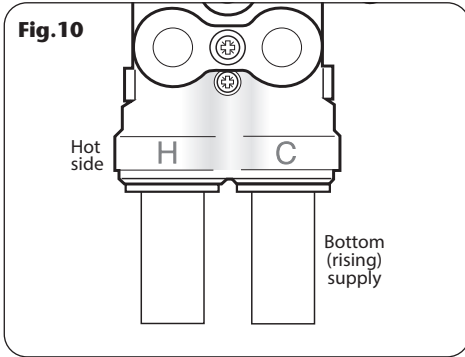

The pipe inlets are marked for hot and cold connections – left-hand side for hot inlet on bottom entry (**fig.10**) and right-hand side for hot inlet on top or rear entry (**fig.11**).

IMPORTANT: The fittings on the inlets are the push-in type. DO NOT insert fingers into the push-in inlet fittings, doing so could cause injury. The pipework must be cut with a pipe cutter and all burrs and rough edges removed from the end of the tube. The fittings can be used with copper and plastic pipe. If using chrome plated copper pipe, remove the first 25mm of plating completely from the connecting surfaces. If not completely removed then the collet will not grip the pipe and under pressure the pipe may be forced out.

Pipework must be clipped or fixed to the wall so that it cannot be moved or removed without the aid of a tool.

Note: The pipe inlets contain filters. These should be periodically removed and cleaned in order to maintain the performance of the shower. See section 'Cleaning the Filters' on how to access them.

IMPORTANT: The inlets contain check valves. Before completing the connection of the water supplies to the shower, flush out the pipework to remove all swarf and system debris that may cause damage to internal parts. This can be achieved by connecting a hose to the pipework and turning on the water supplies long enough to clear the debris to waste.

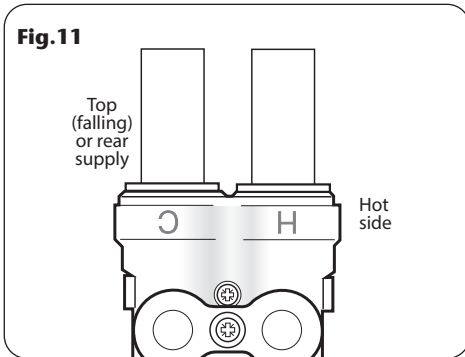

FITTING SHOWER TO THE WALL

Depending on whether top, bottom or rear pipe entry has been chosen, carefully remove the appropriate area using a suitable tool (**figs.12 and 13**).

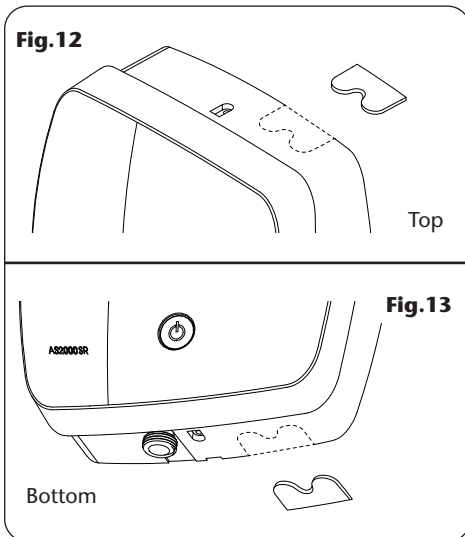
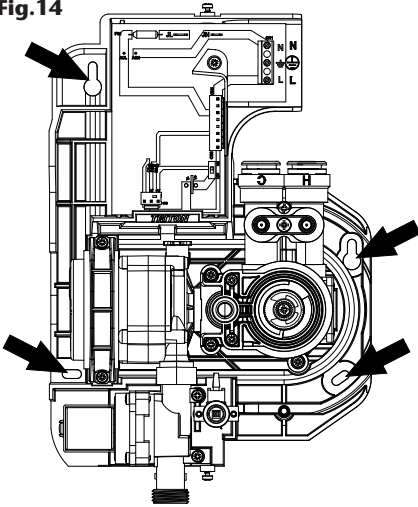

Fig.14



With the cover removed, offer the backplate unit up to the completed pipework and manoeuvre so that the end of the pipes fully enter into the inlet fittings.

Using the backplate as template, mark the positions for the four wall fixing holes (**fig.14**).

Using the pipe removal tool supplied, push back and hold the collets from the pipework to disengage the pipework from the inlets (**fig.15**).

Remove the unit from the wall.

Drill and plug the wall using the appropriate drill and fixings for the wall type i.e. brick, plasterboard.

Note: If fitting rising supplies to the unit, ensure debris does not enter the pipes when drilling the wall.

Offer the backplate back up to the completed pipework and again manoeuvre so that the end of the pipes fully enter into the inlet fittings.

Check the backplate is square and the fixing holes are aligned and secure to the wall.

Once the backplate is secured, add retaining clips to hot and cold inlets as shown in **fig.16**. This will prevent pipes from moving by locking the push fit collets.

Fig.15

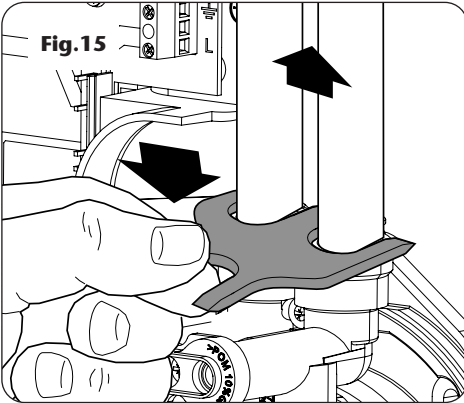
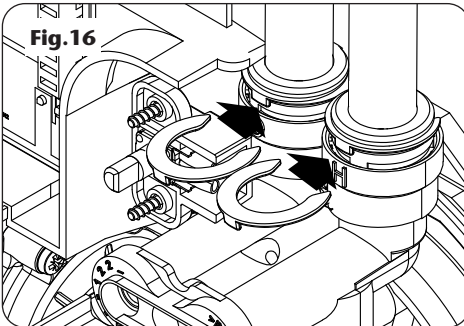

Fig.16



ELECTRICAL CONNECTIONS

This product does not require earthing, however, the supply cable must conform to relevant tables in current IEE regulations. In most cases 0.75 mm² twin cable

If replacing an existing Triton Power Shower then the floating earth can still be terminated at the product terminal block.

IMPORTANT: DO NOT USE ADDITIONAL TERMINAL BLOCKS/WIRES OTHER THAN THOSE FACTORY FITTED INSIDE THE APPLIANCE. FAILURE TO COMPLY WITH THIS WILL INVALIDATE YOUR GUARANTEE.

SWITCH OFF THE ELECTRICITY SUPPLY AT THE MAINS.

Cable entry points are shown in **fig.2**.

Route the cable into the shower, taking care to avoid the area of the wall fixings and connect to the terminal block (**fig.17**) as follows:

Neutral cable to terminal marked **N**

Live cable to terminal marked **L**

Earth cable (if present) to terminal marked **E** ⊕

IMPORTANT: Make sure wires are within the terminal block clamps and not underneath. Fully tighten the terminal block screws and check that no cable insulation is trapped under the screws or clamps.

Note: Fuses do not ensure user protection against electric shock. In the interest of electrical safety, all mains electric and pumped showers should be fitted with a 30mA residual current device (RCD). This may be part of the consumer unit or a separate unit.

DO NOT switch on the electricity supply until the water has been turned on to the unit and connections have been tested for leaks.

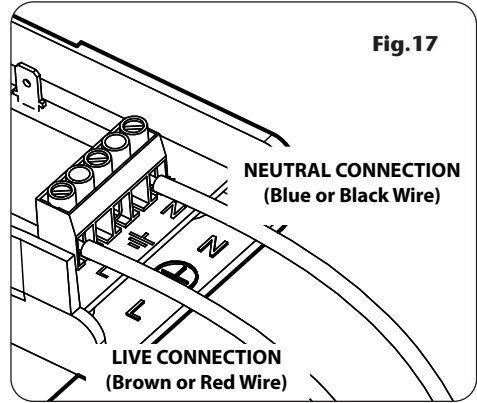

COMMISSIONING

WARNING! BEFORE NORMAL OPERATION OF THE SHOWER, IT IS ESSENTIAL THAT THE COMMISSIONING AND SET UP PROCEDURE ARE CORRECTLY COMPLETED. FAILURE TO DO SO COULD CAUSE THE PUMP TO RUN DRY WITHOUT WATER AND INVALIDATE THE GUARANTEE.

The first operation of the shower is intended to flush out any remaining system debris and to ensure water is purged through the unit. This operation must be carried out with the flexible hose screwed to the shower outlet but without the shower head attached. Make sure the outlet of the hose is directed to waste and the isolating valves controlling the water supply to the unit are fully open.

On the PCB, ensure the dip switch is in the ON position (**fig.18**) to allow commissioning without pump operation.

Fit the cover assembly, attaching the 8 way connector leads to the 8 way pins on the PCB (**fig.19**) – **this will only fit one way**. DO NOT let the cover dangle by the lead. Offer the cover to the unit and temporarily secure using the screws provided.

WARNING!
COVER RETAINING SCREWS
ONLY the SUPPLIED SCREWS should be used. The use of non supplied screws **WILL** invalidate product specifications & guarantee.

Fit the temperature control knob with the override button just to the right of vertical position, ensuring the travel stop engages with the maximum temperature stop (**fig.20**).

Switch on the electricity supply at the isolating switch. Start the unit by pressing the start/stop button (**fig.20**). Water will begin to flow under gravity pressure.

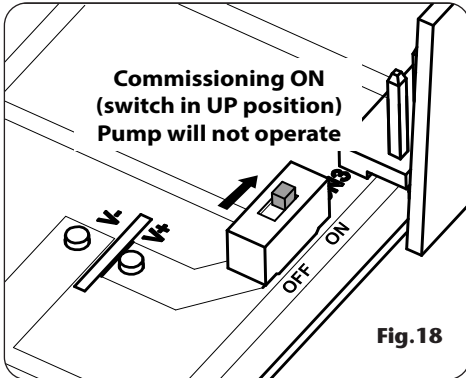
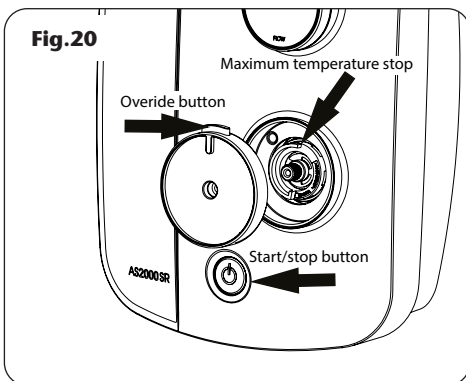
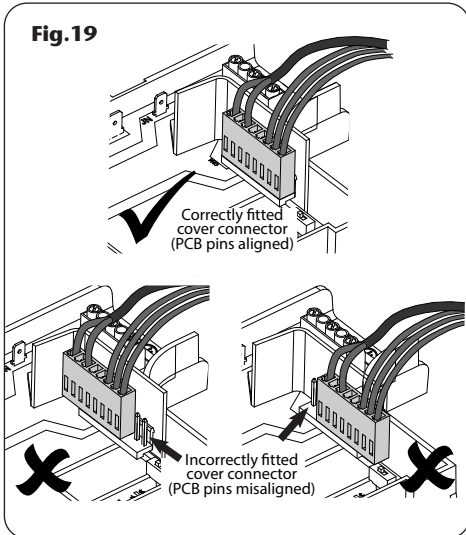

Fig.18



In order to dispel air and to prime both supplies to the shower unit, turn the temperature control several times within its rotational limits.

Note: The temperature control is fitted with a maximum temperature stop, pressing the override is required to achieve fully hot position. **(fig.21). ONCE RESISTANCE IS FELT, DO NOT FORCE THE CONTROL FURTHER.**

To stop the water flow, press the start/stop button to switch off the unit and isolate the electricity supply at the isolating switch. Remove the temperature control knob and front cover assembly, unplugging the 8 way connector lead from the PCB and carefully put both aside.

Check for leaks in the pipework and remedy if necessary. If rear entry has been used then seal around pipes with mastic to prevent the possibility of water entering the wall cavity. **DO NOT** use plaster as this could cause difficulties if maintenance is required at a later date.

Set up Procedure

On the PCB, position the dip switch to the OFF position to allow pump operation **(fig.22)**.

Check the maximum temperature stop is still in position at 12 O'clock **(fig.23)**.

Make sure the start/stop button on the front cover assembly is in the OFF position (flush with the cover). Attach the 8 way connector lead to the 8 way pins on the PCB (refer back to **fig.19**) and offer the front cover assembly to the unit. Ensure the wires are clear of the front cover assembly and secure with the screws provided.

Switch the electricity supply back on at the isolating switch. Make sure both water supplies are still turned on.

Once the installation of the riser rail is complete, the shower will be ready for temperature control set up and then normal operation.

Fig.21

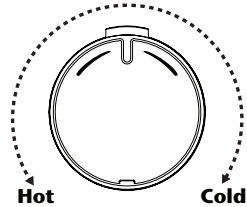

Commissioning OFF
(switch in DOWN position)
Pump will operate

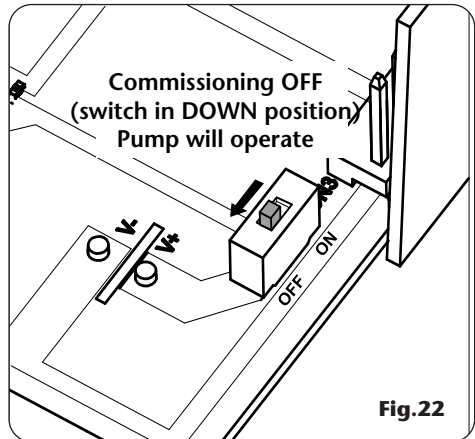
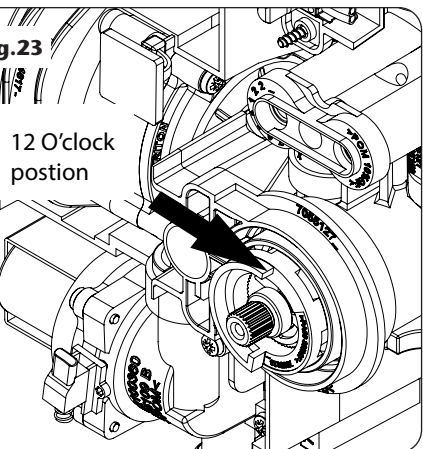
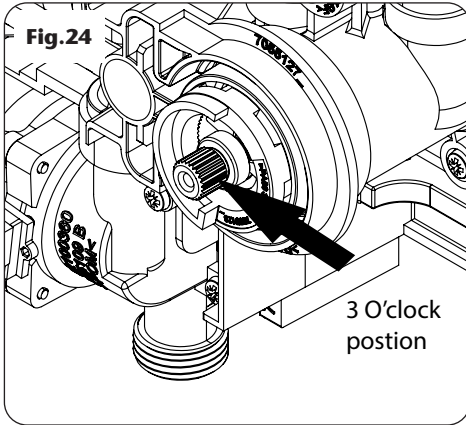

Fig.22

Fig.23





TEMPERATURE CONTROL SET UP

On the temperature valve you will see a mark on the brass valve spindle when positioned at 3 O'clock (**fig.24**), this is the factory setting.

Important

As a safety feature the shower has a built-in maximum temperature stop to prevent accidental rotation to higher temperatures.

The mixed water temperature can be adjusted from cold through to a top limit, which can be preset during installation.

Increasing Maximum Temperature Stop

To increase the maximum temperature above the factory setting, operate the shower unit by pressing the start/stop button and rotate the brass valve spindle anti-clockwise (**fig.25**) until desired temperature is reached, making sure this is a settled temperature from the handset - use the temperature knob to move spindle. This will now become your new maximum temperature stop setting. Do not move the spindle again at this point.

Fit the temperature control knob with the override button just to the right of vertical position, ensuring the travel stop engages with the maximum temperature stop. Operate the shower making sure you have the desired temperature setting, re-adjust if required. Secure the temperature knob in place with the retaining screw and push fit the screw trim into place ensuring the cutout at the bottom of the trim engages with the ridge in the bottom of the screw hole (**fig.26**).

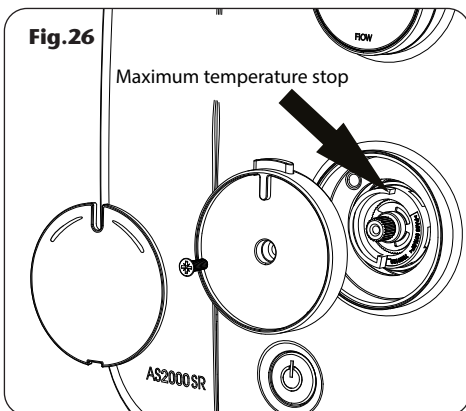
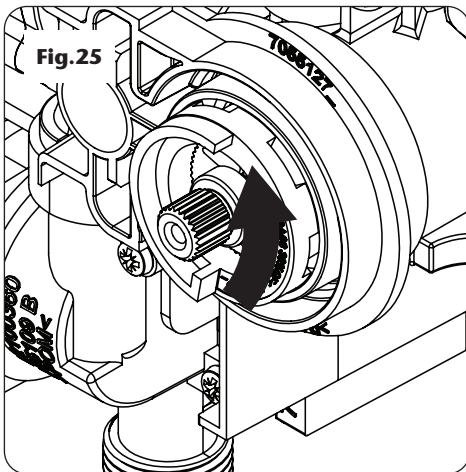

OPERATING THE SHOWER

Make sure all plumbing and electrical supplies are connected and switched on.

To start the shower, press the start/stop button (**fig.27**).

Adjust the flow control (**fig.28**) until the flow rate is satisfactory.

For maximum flow, turn the flow control fully clockwise. For minimum flow, rotate the flow control fully anti-clockwise.

To adjust the water temperature, rotate the temperature control clockwise for cold and anti-clockwise for hot (**fig.29**).

To stop the shower, press the start/stop button once more. This stops the pump and water flow.

The shower should be isolated from the electricity supply after use, unless it is to be used again immediately.

As a safety feature, the temperature control has a built-in stop to prevent accidentally exceeding your highest desired temperature. If adjustment is required see section 'Temperature Control Set up'.

To override this stop, press the button (**fig.26**) while the control is up against the stop and turn the control anti-clockwise to the higher temperature settings. To return to the normal temperature range just turn the temperature control clockwise until it is past the maximum temperature stop. Make sure that the temperature control is in the normal temperature range when the shower is switched off. The stop comes in a factory set position based on water supply temperatures in **SPECIFICATION** on **page 5**.

Note: As the flow control is adjusted it is quite normal for the sound of the pump to alter in pitch.

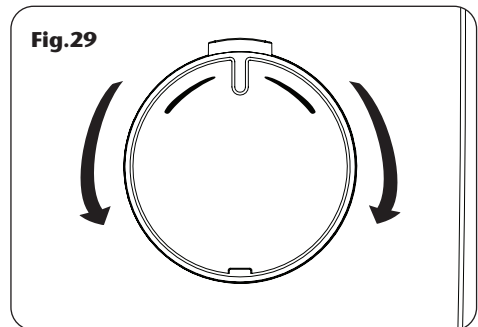
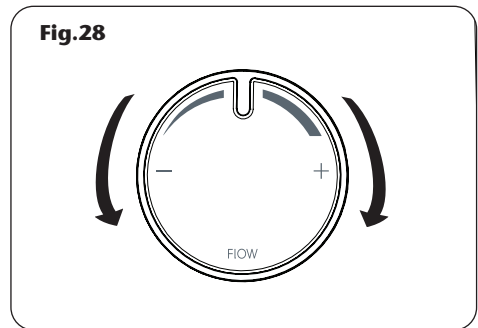
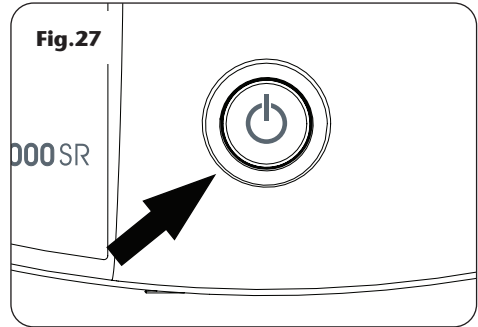

INSTRUCTIONS FOR INSTALLERS AND SERVICE ENGINEERS ONLY

CLEANING THE FILTERS

WARNING!

Switch off the electricity supply and turn off both hot and cold water supplies to the unit before proceeding further.

To remove the cover, first remove the screw trim from the temperature control knob and then remove the retaining screw.

Remove the temperature control.

Remove the top and bottom cover fixing screws and carefully lift the cover away from the backplate.

Note: Be aware of the lead connected to the PCB unit. Carefully pull the lead from the PCB. DO NOT let the cover dangle by the lead.

Remove the single retaining screw from the centre of filter cap (**fig.30**). Carefully remove the filters and the 'O' rings. Thoroughly clean the filters and replace. Refit the filter cap ensuring the 'O' rings are back in position. Secure filter cap with the retaining screw.

Make sure the valve spindle is correctly aligned. See section 'Temperature Control Set Up'.

Offer the cover to the unit and reattach the connector lead to the PCB. Ensure the wires are clear of the cover. Secure the cover with the top and bottom fixing screws.

Refit the temperature knob with the override button just to the right of vertical position, ensuring the travel stop engages with the maximum temperature stop (**fig.26**).

Secure the temperature knob in place with the retaining screw and push fit the screw trim into place.

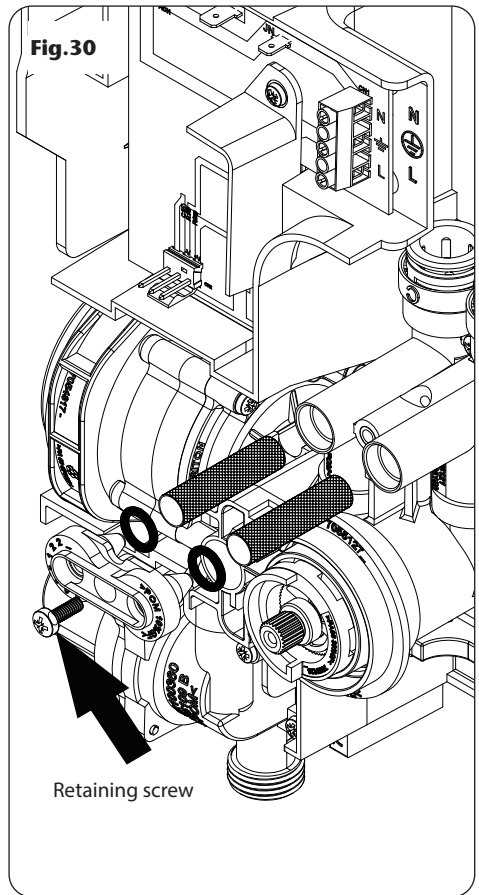

FAULT FINDING

IMPORTANT: Switch OFF the electricity at the mains supply and remove the correct circuit fuse before attempting any fault finding inside the unit.

Any maintenance or repair to the shower must be carried out by a suitably competent person.

In the unlikely event of a fault occurring please contact Triton Customer Experience. DO NOT remove the shower from the installation.

Symptom	Cause	Action
1 Water too hot.	<p>1.1 Not enough cold water flowing through shower.</p> <p>1.2 Increase in the ambient cold water temperature.</p> <p>1.3 Cold inlet filter blocked or check valve sticking.</p> <p>1.4 Cold water supply blocked or cut off.</p>	<p>1.1.1 Turn the temperature control clockwise.</p> <p>1.2.1 Turn the temperature control clockwise.</p> <p>1.3.1 Remove filter and clean. If problem is with check valve, contact Customer Experience.</p> <p>1.4.1 Isolate shower and consult a competent plumber or contact Customer Experience.</p>
2 Water too cold.	<p>2.1 Not enough hot water flowing through shower.</p> <p>2.2 Decrease in ambient cold water temperature.</p> <p>2.3 No hot water in the storage cylinder.</p> <p>2.4 Hot inlet filter blocked or check valve sticking.</p> <p>2.5 Hot water supply blocked or otherwise cut off.</p>	<p>2.1.1 Turn temperature control anti-clockwise.</p> <p>2.2.1 Turn temperature control anti-clockwise.</p> <p>2.3.1 Turn shower off and wait for hot water cylinder to reheat.</p> <p>2.4.1 Remove filter and clean. If problem is with check valve, contact Customer Experience.</p> <p>2.5.1 Turn shower off. Consult a competent plumber or contact Customer Experience.</p>
3 Pump does not operate.	<p>3.1 Interrupted power supply.</p> <p>3.2 Electrical malfunction.</p> <p>3.3 Motor overheated.</p> <p>3.4 Start/stop switch not connected.</p>	<p>3.1.1 Blown fuse. Check supply. Renew fuse. If it fails again consult a competent electrician.</p> <p>3.1.2 Power cut. Check other appliances and if necessary, contact local Electricity Supply Co.</p> <p>3.2.1 Consult a competent electrician or contact Customer Experience.</p> <p>3.3.1 Thermal protection on motor has operated. Allow appliance to cool and reset itself. If it persists, contact Customer Experience</p> <p>3.4.1 Remove cover and connect start/stop switch.</p>

Power Shower

FAULT FINDING

Symptom	Cause	Action
4 Water does not flow or is reduced.	4.1 Water supplies cut off. 4.2 Shower blocked or air in the system. 4.3 Shower head blocked. 4.4 Blocked filters.	4.1.1 Check water elsewhere in house and if necessary contact the local Water Company. 4.2.1 Switch off shower and contact Customer Experience. 4.3.1 Clean shower head. 4.4.1 Clean filters.
5 Cross flow of hot and cold water into system.	5.1 Dirt/debris in check valves.	5.1.1 Isolate water to unit. Remove check valves. Clean and replace.
6 Water dripping from shower head when turned off.	6.1 Debris in solenoid valve. 6.2 Potentiometer faulty.	6.1.1 Call Customer Experience. 6.2.1 Call Customer Experience.
7 Pump is noisy.	7.1 Air lock in pump. 7.2 Faulty pump.	7.1.1 Call Customer Experience. 7.2.1 Replace pump.

To purchase a genuine Triton spare part for your product, please visit **www.tritonshowers.co.uk/spares** for product codes and prices. Alternatively please call our Customer Experience team on **024 7637 2222** to order direct. Please have your model name available.

WEEE Directive – Policy Statement

As a producer and a supplier of water heaters, Triton Showers is committed to the protection of the environment via our own environmental policy and compliance with the **WEEE directive**.

Triton Showers is fully registered with the Environment Agency under the following scheme:

Repic: Producers take-back scheme (PTS), registration number WEE/EJ3466QV

Valpak: Distributor Takeback Scheme (DTS), registration number DTS-700160

All our electric products are labelled accordingly with the crossed out wheeled bin symbol. This indicates, for disposal purposes at end of life, that these products must be taken to recognised collection points, such as local authority sites/local recycling centres; this will be free of any charges. **Do not return to Triton Showers.**



UK SERVICE POLICY

In the event of a product fault or complaint occurring, the following procedure should be followed:

DO NOT REMOVE THE PRODUCT

1. Telephone Customer Experience on **024 7637 2222** having available your details including post code, the model number and power rating of the product, together with the date of purchase and, where applicable, details of the particular fault.
2. If required, the Customer Experience Advisor will arrange for a qualified engineer to call.
3. All products attended to by a Triton service engineer must be installed in full accordance with the Triton installation guide applicable to the product; this can be downloaded free at www.tritonshowers.co.uk/guides.
4. Our engineer will require local parking and if a permit is required, this must be available to the engineer on arrival at the call.
5. If loft access is required for isolation or to complete a repair, the loft must have a fixed access ladder and be boarded, with appropriate lighting from the access point to and around the repair area.
6. It is essential that you or an appointed representative, who must be over 18 years of age, is present for the duration of the service engineer's visit. If the product is in guarantee you must produce proof of purchase.
7. Where a call under the terms of guarantee has been booked and the failure is not product related (i.e. scaling and furring, incorrect water pressure, pressure relief device operation or electrical/plumbing installation fault) a charge will be made. A charge will also be issued if nobody is at the property when the service engineer calls or adequate parking/permit is not available.
8. If the product is no longer covered by the guarantee an up-front fixed fee will be charged before the site visit.
9. Your receipt must be retained as proof of purchase. Should proof of purchase not be available on an "in-guarantee" call, or should the service engineer find that the product is no longer under guarantee, the engineer will charge the same fixed price and will request payment prior to departing. If payment is not made on the day an administration charge will be added to the fixed charge.
10. If a debt is outstanding from a previous visit, or from any other Triton purchase, Triton reserves the right to withhold service until the debt has been settled.
11. Triton takes the health, safety and wellbeing of its employees very seriously and expects customers to treat all staff members with respect. Should any employee feel threatened or receive abuse, either verbally or physically, Triton reserves the right to withhold service.

Replacement Parts Policy

In line with AMDEA guidelines, Triton retains functional spares for as long as there is a market for them and in most cases, well beyond. Due to the vast array of product types, the life cycle of products can vary and therefore so can the length of time parts can be supplied. Spare parts can be ordered via our online spare parts store or by telephoning Triton Customer Experience Team on **024 7637 2222**. Payment should be made by credit / debit card (excluding American Express or Diners Card). Payment can also be made by pre-payment of a pro-forma invoice, by cheque or postal order.

Telephone orders are based on information given during the call. Before contacting Triton, please verify your requirements using the Triton website or your professional installer. Triton cannot accept liability for incorrect part identification.

Triton Showers
Triton Road
Nuneaton
Warwickshire, CV11 4NR

Triton is a division of Norcross Group (Holdings) Limited

Triton reserve the right to change product specification without prior notice. E&OE. © TRITON SHOWERS 2026

TRITON UK STANDARD GUARANTEE

This guarantee applies only to products installed within the United Kingdom and does not apply to products used commercially. This guarantee does not affect your statutory rights.

With the exception of accessories, Triton guarantee the product against all manufacturing defects for a period of **1 year** (for domestic use only) from the date of purchase, provided that it has been installed by a competent person in full accordance with the fitting instructions.

All accessories such as shower heads, hoses and riser rails carry a **1 year** parts only guarantee against manufacturing defects.

Any part found to be defective during this guarantee period we undertake to repair or replace at our option without charge, so long as it has been properly maintained and operated in accordance with the operating instructions and has not been subject to misuse or damage. This product must not be taken apart, modified or repaired except by a person authorised by Triton.

What is not covered:

1. Breakdown due to:
 - a) use other than domestic use by the property occupants;
 - b) wilful act or neglect;
 - c) any malfunction resulting from the incorrect use or quality of electricity, gas or water or incorrect setting of controls;
 - d) failure to install in accordance with this installation guide.
2. Claims for missing parts once the product has been installed.
3. Repair costs for damage caused by foreign objects or substances.
4. Total loss of the product due to non-availability of parts.
5. Compensation for loss of use of the product or consequential loss of any kind.
6. Call out charges due to an abortive visit or where no fault has been found with the appliance.
7. The cost of repair or replacement of isolating switches, electrical cable, fuses and/or circuit breakers or any other accessories installed at the same time. Replacement of a Pressure Relief Device that only activates when the shower outlet is blocked is also excluded.
8. The cost of routine maintenance, adjustments, overhaul modifications or loss or damage arising therefrom, including the cost of repairing damage, breakdown, malfunction caused by corrosion, furring, frost or exposure to freezing conditions.
9. Callout charges where the water supply cannot be isolated, this includes consequential losses arising from unserviceable supply valves, or inaccessible product or valves located in a loft space without suitable access.

For the latest Terms & Conditions please see:

www.tritonshowers.co.uk/terms

PLEASE NOTE PRODUCT REGISTRATION IS ONLY AVAILABLE TO UNITS PURCHASED & INSTALLED IN THE UK

Customer Experience: **024 7637 2222**
Trade Installer Hotline: **024 7637 8344**
www.tritonshowers.co.uk
E-mail: CXsupport@tritonshowers.co.uk
E-mail: technical@tritonshowers.co.uk